



02-0301 / 02-0304



INTERPHONE VIDEO VENDONE ENCASTRE

VENDONE BUILT-IN VIDEO INTERCOM

VENDONE UNTERPUTZ-VIDEO-SPRECHANLAGE

VENDONE INBOUW VIDEO INTERCOM

VENDONE INDBYGGET VIDEO INTERCOM

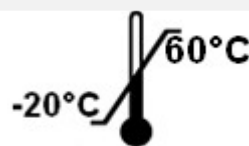

intratone

INTRATONE
ZI de Maunit 370 rue de Maunit
85290 MORTAGNE SUR SEVRE
FRANCE

APPEL AUDIO / AUDIO CALL / AUDIOANRUF / AUDIO CALL / AUDIO CALL



APPEL VIDEO / VIDEO CALL / VIDEOANRUF / VIDEO CALL / VIDEOOPKALD



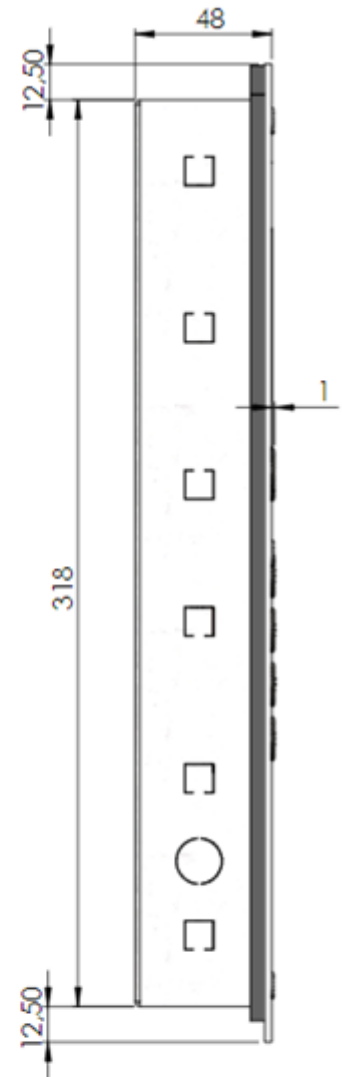
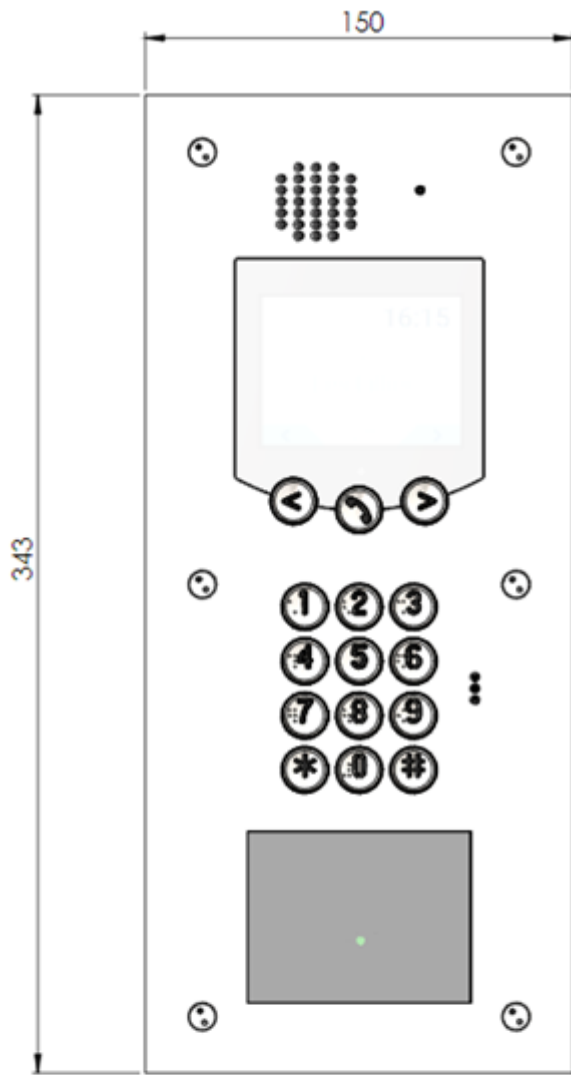
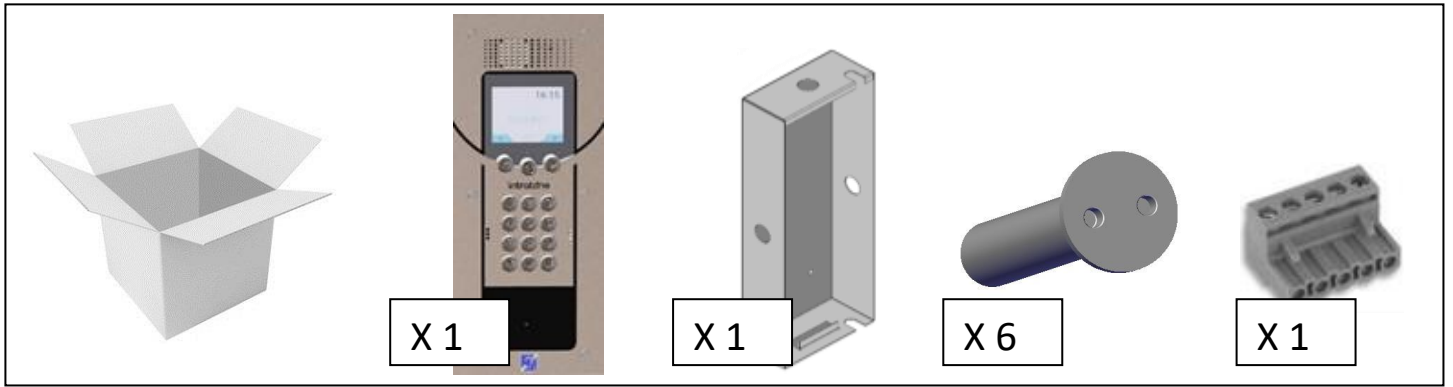

Montage / Fitting / Montage / Montage / Montering

1

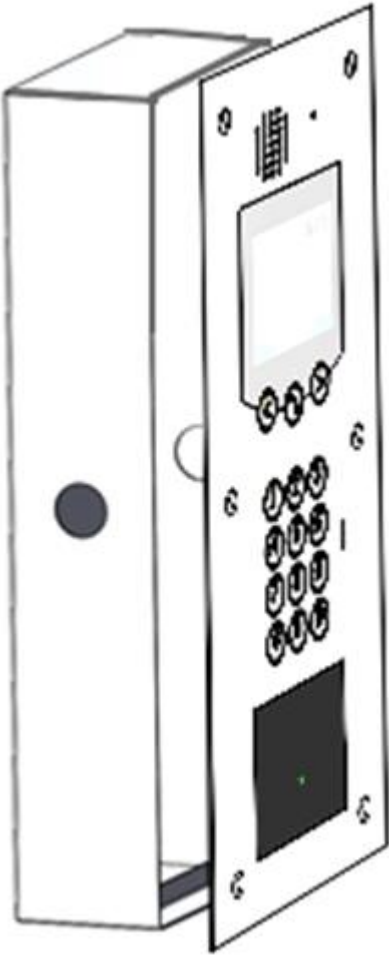

2

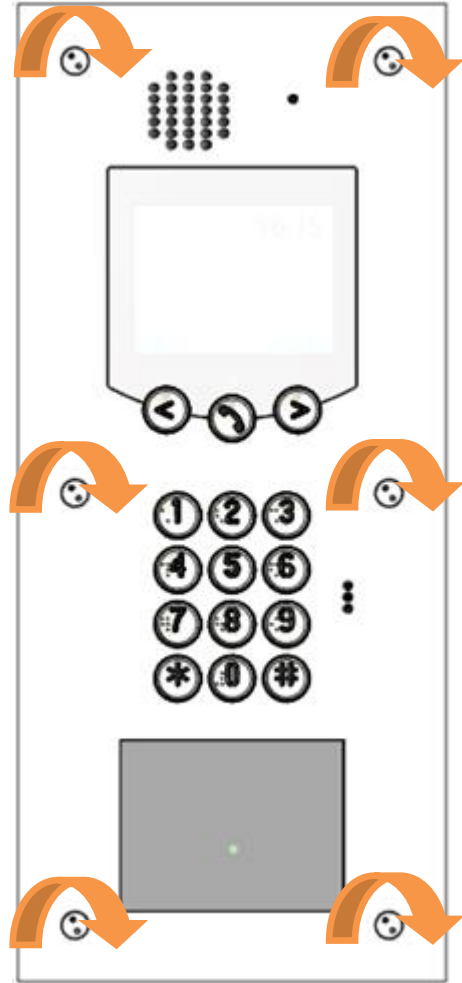

3

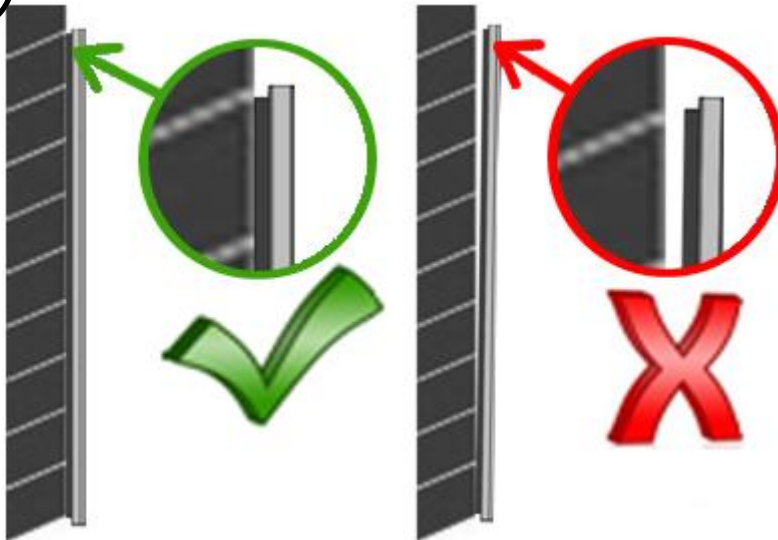

03-0102

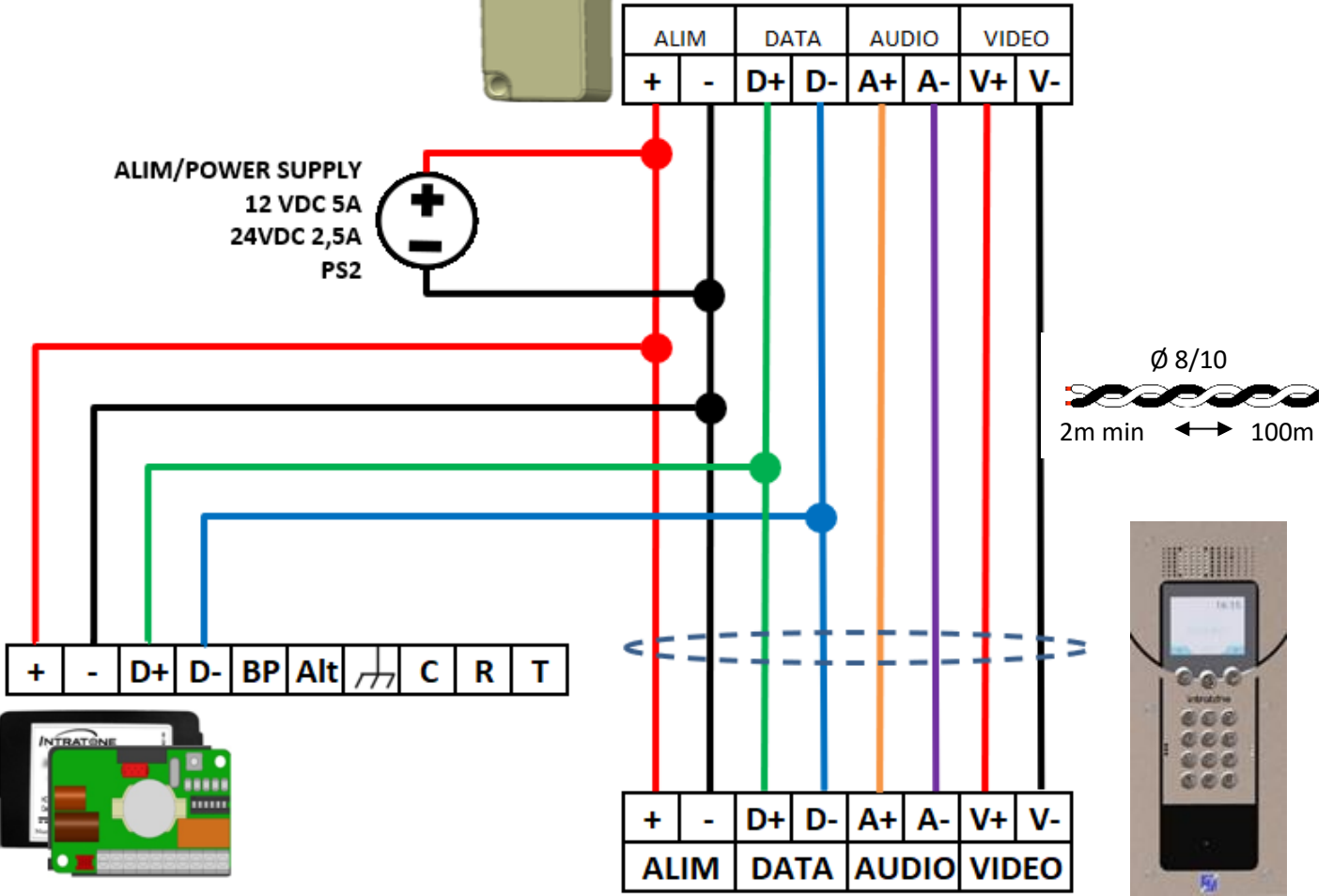
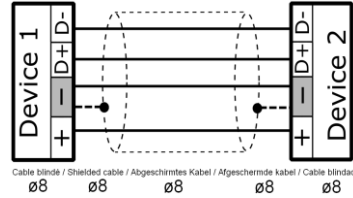

VENTOUSE / MAGNET LOCK

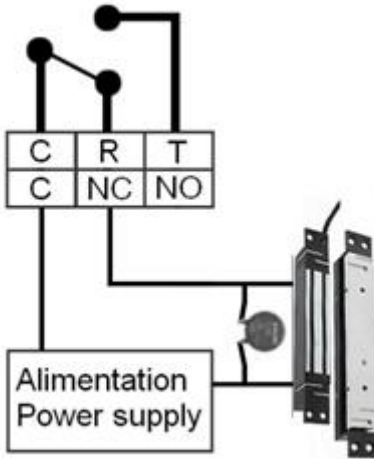

GACHE / ELECTRIC LOCK

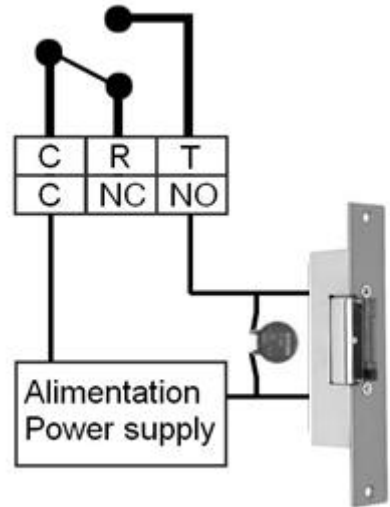

03-0101

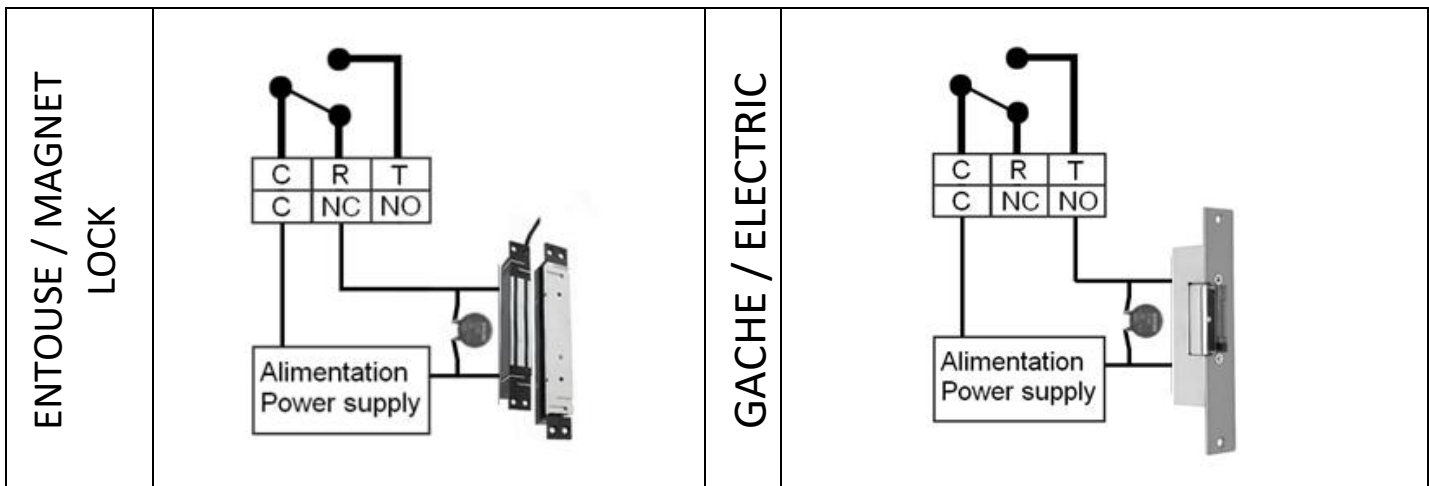
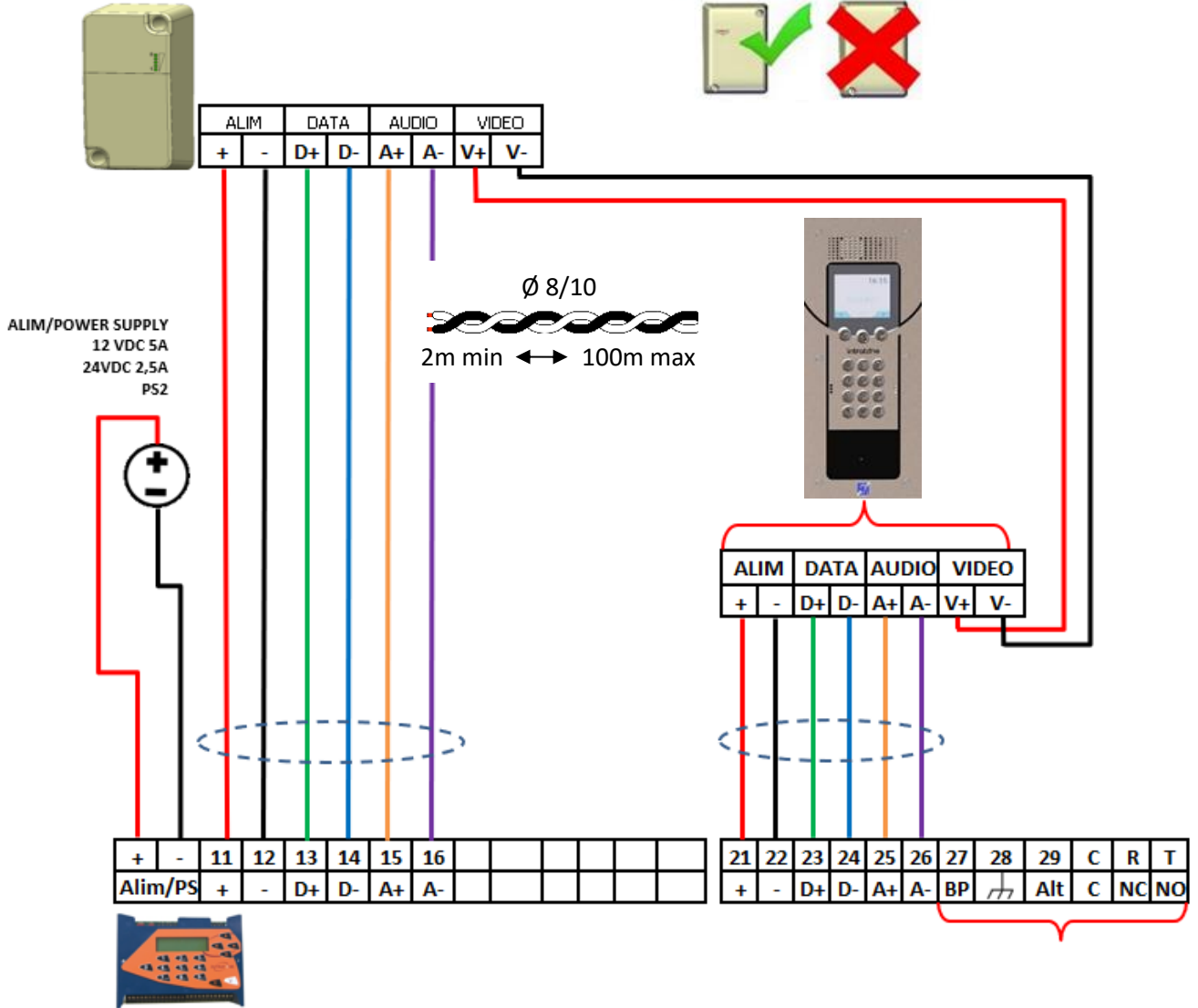
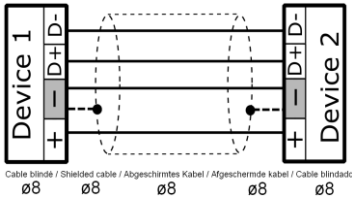



1

Aller dans la résidence



2

Cliquer "Créer" et choisir votre interphone, nommez-le

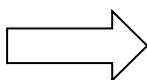

02-0301 / 02-0304

3

Il faut maintenant "Configurer la centrale"

Configurer la centrale

4

Ajouter des badges, des appartements et des résidents avec « Créer »



5

Aller dans « Codes » pour créer des codes clavier

Codes

6

Mettre à jour la résidence

Résidences

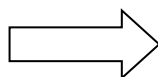

Mettre à Jour

LOGO

Il est possible de modifier le logo afficher sur l'écran. Sur le site de gestion, sélectionner « Compte » puis « Logo ». Choisir « Télécharger un logo ». Jpeg et png sont acceptés.

1

Go to the residence 

2

Click "Create" and choose your intercom, name it

 →  **02-0301 / 02-0304**



3

Now you need to "Central unit settings".



4

Add fobs, apartments and residents with "Create".

 →  



5

Go to "Codes" to create keypad codes



6

Update the residence

 → 

LOGO

It is possible to change the logo displayed on the screen. On the management site, select "Account" then "Logo". Choose "Upload a logo". Jpeg, png and gif are accepted.



1

Gehe zur Wohnanlagen 

2

Klicken Sie auf "Erstellen" und wählen Sie Ihre gegensprechanlage, benennen Sie sie

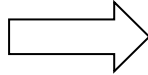

02-0301 / 02-0304

3

Jetzt müssen Sie " konfigurieren der Zentrale"

Konfigurieren der Zentrale

4

Fügen Sie Badges, Apartments und Bewohner mit "Create" hinzu

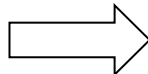

5

Gehen Sie zu "Codes", um Tastaturcodes zu erstellen

Codes

6

Aktualisieren Sie immer die Wohnanlagen

Wohnanlagen

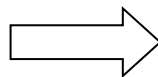

Aktualisieren

LOGO

Es ist möglich, das auf dem Bildschirm angezeigte Logo zu ändern. Wählen Sie auf der Verwaltungssite "Konto" und dann "Logo". Wählen Sie "Logo hochladen". JPEG, PNG und GIF werden akzeptiert.



1

Ga naar de woning / På vej til bopælen



2

Klik op "Maken" en kies uw Video-intercom, noem het
Klik på "Opret", og vælg din intercom, navngiv den

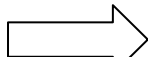

02-0301 / 02-0304

3

Nu moet u "De centrale configureren"

De centrale configureren

Nu skal du "Konfigurere anlægget".

Configurar la central

4

Voeg badges, appartementen en bewoners toe met "Create"

Tilføj badges, lejligheder og beboere med "Opret".

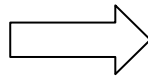

5

Ga naar "Codes" om toetsenbordcodes te maken

Codes

Gå til "Koder" for at oprette tastaturkoder

Códigos

6

Voordat u vertrekt, moet u de accommodatie altijd bijwerken

af boligen

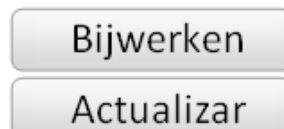
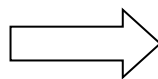

LOGO

Het is mogelijk om het logo dat op het scherm wordt weergegeven te wijzigen. Selecteer op de beheersite "Account" en vervolgens "Logo". Kies "Upload een logo". Jpeg, png en gif worden geaccepteerd.

Det er muligt at ændre det logo, der vises på skærmen. På administrationswebstedet skal du vælge "Account" (konto) og derefter "Logo" (logo). Vælg "Download et logo". Jpeg og png accepteres.

Réception réseau / Network reception / Netzwerkkempfang / Netwerk ontvangst /
 Netværksmodtagelse

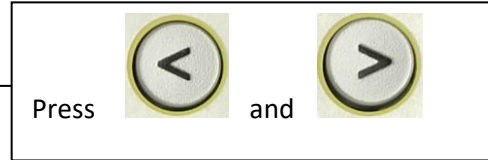
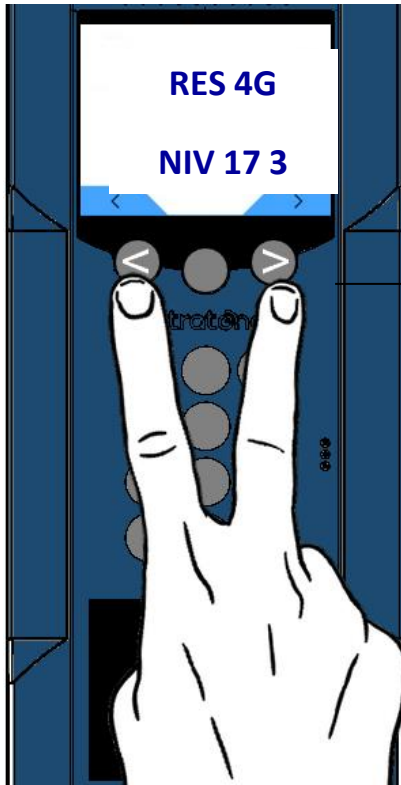

RES 4G

	AUDIO CALL	VIDEO CALL
RES GSM	✓	✗
RES 3G	✓	✓
RES 4G	✓	✓

NIV 17 3

Le premier chiffre donne le niveau sur 31 (Ici 17/31)	Le second chiffre donne le niveau sur 5 (Ici 3/5)
The first digit gives the level out of 31 (Here 17/31)	The second digit gives the level out of 5 (Here 3/5)
Die erste Ziffer gibt das Level von 31 (hier 17/31)	Die zweite Ziffer gibt die Stufe von 5 (hier 3/5)
Het eerste cijfer geeft het niveau uit 31 (hier 17/31)	Het tweede cijfer geeft het niveau van 5 (Here 3/5)
Det første tal angiver niveauet ud af 31 (her 17/31)	Det andet tal angiver niveauet ud af 5 (her 3/5)

Dépannage

 FR : Quelle est la panne ?	Comment résoudre la panne !
Message sur afficheur : « Défaut de communication »	- Vérifier le câblage entre le bloc, l'interphone et la centrale : D+/D- - L'afficheur doit indiquer le message d'accueil.
Touches et/ou écran LCD non rétro-éclairés	- Mauvais câblage sur les borniers + et ou –
Touches rétro-éclairées alors que l'afficheur ne l'est pas (ou l'inverse)	Contacter nos services techniques
Au passage d'un badge, la led du lecteur s'allume vert pourtant la porte ne s'ouvre pas.	- Relais de la centrale ne fonctionne pas. - Vérifier le câblage entre la centrale et la porte
L'interphone dit « Appel en cours » mais le résident n'entend pas le visiteur	Vérifier le câblage A+ / A-
L'interphone dit « Appel impossible » sans tonalité d'appel	Vérifier le câblage vers le module et niveau des leds Réseau téléphonique non disponible
Le résident ne voit pas le visiteur sur son téléphone	- Vérifier le câblage V+ / V-

Garanties de fonctionnement:

L'Interphone Vidéo Vendone est garanti dans une plage de température comprise entre -20°C et +60°C et pour une humidité relative maximum de 70%.

Doit être posé selon le sens Haut / Bas préconisé sur l'appareil.

L'installation doit être réalisée par du personnel qualifié possédant les connaissances nécessaires à un montage sûr de l'équipement.

Ne pas installer à l'extérieur en cas de températures extrêmes (Finlande, Suède, Norvège).

Ce kit comprend les éléments nécessaires pour assurer une installation sûre de l'équipement.



Recyclage du produit en fin de vie:

L'Interphone Vidéo Vendone et ses accessoires ne doivent pas être mis au rebut avec les déchets municipaux non triés, mais doivent suivre la filière de collecte et de recyclage des produits DEEE (Déchets d'Equipements Electriques et Electroniques).



Déclaration de conformité simplifiée

Le soussigné, COGELEC, déclare que l'équipement radioélectrique du type contrôle d'accès pour l'habitat collectif est conforme à la directive 2014/53/UE (RED). Le texte complet de la déclaration UE de conformité est disponible à l'adresse internet suivante : <http://certificates.intratone.com/>

Spécifications techniques		
Tensions d'alimentation	12 – 24Vdc max. (ES1) < 100W (PS2)	
Caractéristiques radio	100 Hz - 9 kHz	< 120 dBµA/m @10m
	119 kHz - 135 kHz	< 66 dBµA/m @10m
	13.553 MHz - 13.567 MHz	< 60 dBµA/m @10m
	433.05 MHz – 434.79 MHz	Catégorie Récepteur = 2
Gamme de températures en stockage	-20 à +60°C	
Gamme de températures en fonctionnement	-20 à +60°C	
Environnement	IP54	

Help

 EN : What is the failure ?	How to solve the problem!
Message on display: "Communication fault"	- Check the wiring between the block, the board and the central unit: D + / D- - The display must indicate the greeting.
Keys and or LCD screen not backlit	- Bad wiring on + and or - terminal blocks
Backlit keys while the display is not (or vice versa)	Contact our technical services
When passing a badge, the LED of the reader turns green, but the door does not open.	- Relay of the central does not work. - Check wiring between the control panel and the door
The interphone says "Call in progress" but the resident does not hear the visitor	Review A + / A- wiring
The platinum says "Call impossible" without call tone	Check wiring to the block and leds level Phone network not available
The resident does not see the visitor in his phone	-Check wiring V + / V-

Warranty operating guarantees:

The Vendone video intercom is guaranteed within a temperature range of -20°C and +60°C and at a relative humidity level not exceeding 70%.

It must be installed according to the Top/Bottom directions given in these instructions and on the device.

The installation must be carried out by qualified personnel with the necessary knowledge for a safe assembly of the equipment.

Do not install outdoors in extreme temperatures (Finland, Sweden, Norway).

This kit includes the necessary elements to ensure a safe installation of the equipment.



End-of-life recycling of the product:

The Vendone video intercom and its accessories must not be discarded with unsorted municipal waste, but must be disposed of via the WEEE (Waste Electrical and Electronic Equipment) collection and recycling system.



Simplified declaration of conformity

The undersigned, COGELEC, declares that access control type radio equipment for collective housing is in compliance with Radio Equipment Regulations 2017 (SI 2017/1206). The full text of the declaration of conformity is available at the following internet address: <http://certificates.intratone.com/>



Simplified declaration of conformity

The undersigned, COGELEC, declares that access control type radio equipment for collective housing is in compliance with Directive 2014/53/EU (RED). The full text of the EU declaration of conformity is available at the following internet address: <http://certificates.intratone.com/>

Technical specifications :		
Operating voltage	12 – 24Vdc max. (ES1) < 100W (PS2)	
Radio frequency characteristics	100 Hz - 9 kHz	< 120 dBµA/m @10m
	119 kHz - 135 kHz	< 66 dBµA/m @10m
	13.553 MHz - 13.567 MHz	< 60 dBµA/m @10m
	433.05 MHz – 434.79 MHz	Receiver category = 2
Storage Temperatures range	-20 to +60°C	
Operating Temperatures range	-20 to +60°C	
Operating environment	IP54	

Hilfe

 DE : Was ist der Zusammenbruch?	Wie man das Problem löst!
Meldung auf dem Display: "Kommunikationsfehler"	Überprüfen Sie die D + / D- Verdrahtung - Das Display muss die Begrüßung anzeigen.
Tasten und / oder LCD-Bildschirm nicht hinterleuchtet	- Schlechte Verdrahtung an + und oder - Klemmen
Hintergrundbeleuchtete Tasten während der Anzeige nicht (oder umgekehrt)	Kontaktieren Sie unseren technischen Service
Beim Übergeben eines Ausweises wird die LED des Lesers grün, aber die Tür öffnet sich nicht.	- Relais der Zentrale funktioniert nicht. - Überprüfen Sie die Verkabelung zwischen dem Bedienfeld und der Tür
Das Interphone sagt "Anruf läuft", aber der Bewohner hört den Besucher nicht	Überprüfen Sie die A + / A-Verdrahtung
Das Platin sagt "Anruf unmöglich" ohne Rufton	Überprüfen Sie die Verkabelung zum Block und zur LED-Ebene Das Telefonnetzwerk ist nicht verfügbar
Der Bewohner sieht den Besucher nicht in seinem Telefon	- Verdrahtung prüfen V + / V-

Funktionsgarantien:

Der Betrieb des Vendone Video-Gegensprechanlage ist für eine Temperaturspanne zwischen -20 °C und +60 °C und für eine relative Luftfeuchtigkeit von 70 % gewährleistet.

Muss wie auf dem Gegensprechanlage angegeben in der Richtung Oben/Unten eingebaut werden.

Die Installation muss von qualifiziertem Personal mit den notwendigen Kenntnissen für eine sichere Montage der Ausrüstung durchgeführt werden.

Nicht im Freien bei extremen Temperaturen installieren (Finnland, Schweden, Norwegen).

Dieses Kit enthält die notwendigen Elemente, um eine sichere Installation des Geräts zu gewährleisten.



Entsorgung des ausgedienten Geräts:

Das Vendone Video-Gegensprechanlage und sein Zubehör dürfen nicht mit unsortiertem Hausmüll entsorgt werden, sondern müssen an Sammel- und Recyclestellen für Elektro- und Elektronikgeräte-Abfall abgegeben werden.

Vereinfachte Konformitätserklärung

Der Unterzeichnete, COGELEC, erklärt, dass funkgesteuerte Zugangskontrollgeräte für den kollektiven Wohnungsbau der



Richtlinie 2014/53 / EU (RED) entsprechen. Der vollständige Text der EU-Konformitätserklärung ist unter folgender Internetadresse verfügbar: <http://certificates.intratone.com/>

<i>Technische Spezifikationen :</i>		
Betriebsspannung	12 – 24Vdc max. (ES1) < 100W (PS2)	
Hochfrequenzeigenschaften	100 Hz - 9 kHz	< 120 dBµA/m @10m
	119 kHz - 135 kHz	< 66 dBµA/m @10m
	13.553 MHz - 13.567 MHz	< 60 dBµA/m @10m
	433.05 MHz – 434.79 MHz	Empfänger-Kategorie = 2
Lagertemperaturen reichen	-20 à +60°C	
Betriebstemperaturen reichen	-20 à +60°C	
Schutzklasse	IP54	

Helpen

 NL : Wat is de verdeling?	Hoe het probleem op te lossen!
Bericht op display: "Communicatiefout"	- Controleer D + / D- bedrading - Het display moet de begroeting aangeven.
Toetsen en/of LCD-scherm niet verlicht	- Verkeerde bedrading op + en of - aansluitklemmen
Verlichte toetsen terwijl het display dat niet is (of omgekeerd)	Neem contact op met onze technische dienst
Bij het aanbieden van een badge wordt de LED van de lezer groen, maar de deur gaat niet open.	- Relais van de centrale werkt niet. - Controleer de bedrading tussen het bedieningspaneel en de deur
De intercom zegt " Bezig met bellen " maar de bewoner hoort de bezoeker niet	Controleer A + / A- bedrading
Het paneel zegt " Bellen niet mogelijk " zonder beltoon	Controleer de bedrading naar het blok en het niveau van de LEDs Mobiel netwerk niet beschikbaar
De bewoner ziet de bezoeker niet in zijn telefoon	- Controleer de bedrading V + / V-

Werkingsgarantie:

De Vendone Video-intercom werkt bij temperaturen tussen -20 °C et +60 °C en bij een relatieve vochtigheidsgraad van ten hoogste 70%.

Moet gemonteerd worden met de juiste zijden naar boven, zoals aangegeven op de intercom.

De installatie moet worden uitgevoerd door gekwalificeerd personeel met de nodige kennis voor een veilige montage van de apparatuur.

Installeer niet buitenshuis bij extreme temperaturen (Finland, Zweden, Noorwegen).

Deze set bevat de nodige elementen om een veilige installatie van de apparatuur te garanderen.

Recycling aan het einde van de levensduur:



Het Video-intercom Vendone en zijn toebehoren mogen niet als restafval worden afgevoerd, maar moeten ingeleverd worden bij inzamelpunten voor elektrische of elektronische apparatuur.

Vereenvoudigde verklaring van overeenstemming



Ondergetekende, COGELEC, verklaart dat radioapparatuur voor toegangscontrole voor collectieve huisvesting voldoet aan Richtlijn 2014/53 / EU (RED). De volledige tekst van de EU-conformiteitsverklaring is beschikbaar op het volgende internetadres: <http://certificates.intratone.com/>

Technische Specificaties		
Voedingsspanningen	12 – 24Vdc max. (ES1) < 100W (PS2)	
Radio kenmerken	100 Hz - 9 kHz	< 120 dBµA/m @10m
	119 kHz - 135 kHz	< 66 dBµA/m @10m
	13.553 MHz - 13.567 MHz	< 60 dBµA/m @10m
	433.05 MHz – 434.79 MHz	Ontvanger categorie = 2
Temperatuurbereik bij opslag	-20 à +60°C	
Bedrijfstemperatuurbereik	-20 à +60°C	
IP-waarde	IP54	

Fejlfinding

 DK : Hvad er problemet?	Sådan løser du problemet!
Meddelelse på displayet: "Kommunikationssvigt"	- Kontroller ledningerne mellem enheden, intercomen og centralenheden: D+/D-. - Velkomstmeddelelsen skal vises på displayet.
taster og/eller LCD-skærm uden baggrundsbelysning	- Forkert ledningsføring på + og eller - terminalerne
Baggrundsbelyste taster, når displayet ikke er det (eller omvendt)	Kontakt vores tekniske tjenester
Når et badge er passeret, lyser læserens lysdiode grønt, men døren åbnes ikke.	- Kontrolenhedens relæ virker ikke. - Kontroller ledningerne mellem styreenhed og dør
Intercom'en siger "Samtale i gang", men beboeren kan ikke høre den besøgende	Kontroller A+ / A- ledningerne
Intercom'en siger "Opkald ikke muligt" uden en opkaldstone	Kontroller ledninger til modulet og niveauet af lysdioder Telefonnettet er ikke tilgængeligt
Beboeren kan ikke se den besøgende på sin telefon	- Kontroller V+ / V- ledningerne

Driftsgarantier:

Vendone Video Intercom er garanteret til at fungere inden for et temperaturområde på -20 °C til +60 °C og en maksimal relativ luftfugtighed på 70 %.

Den skal installeres i den retning op/ned, som anbefales på enheden.

Installationen skal udføres af kvalificeret personale med den nødvendige viden for at sikre en sikker installation af udstyret.

Må ikke installeres udendørs ved ekstreme temperaturer (Finland, Sverige, Norge).

Dette sæt indeholder de nødvendige elementer til at sikre en sikker installation af udstyret.



Genanvendelse af produktet ved slutningen af dets levetid:

Vendone Video Intercom og dets tilbehør må ikke bortskaffes sammen med usorteret kommunalt affald, men skal følge WEEE-ordningen (Waste Electrical and Electronic Equipment) for indsamling og genbrug.

Forenklet overensstemmelseserklæring



Undertegnede, COGELEC, erklærer, at radioudstyr af adgangskontroltypen til kollektive boliger er i overensstemmelse med direktiv 2014/53/EU (RED). Den fulde tekst af EU-overensstemmelseserklæringen er tilgængelig på følgende webadresse: <http://certificates.intratone.com/>

Tekniske specifikationer		
Forsyningsspændinger	12 – 24Vdc max. (ES1) < 100W (PS2)	
Radioegenskaber	100 Hz - 9 kHz	< 120 dBµA/m @10m
	119 kHz - 135 kHz	< 66 dBµA/m @10m
	13.553 MHz - 13.567 MHz	< 60 dBµA/m @10m
	433.05 MHz – 434.79 MHz	Ontvanger categorie = 2
Lagertemperaturområde	-20 à +60°C	
Driftstemperaturområde	-20 à +60°C	
IP-grad	IP54	